

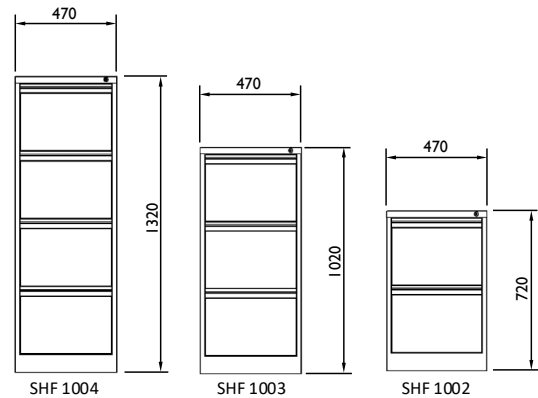

Filing Solutions

Cabinets, pedestals, caddies and all the accessories you need.

Filing Cabinets



Features

- Strong steel construction
- Welded internal and base frame for extra strength and rigidity
- Double extension steel ball bearing runners for smooth operation
- Full drawer extension for easy access to all files/contents
- Heavy-duty 35kg Drawer load capacity (UDL)
- Supplied with Anti Tilt system for safer operation
- Full height powder coated drawer body
- Drawer retention system ensures closed drawers stay shut
- Positive locking system for added security
- Complete with two keys
- Durable oven baked, powder coat finish
- Warranty: 5 years

Colour Options

Standard Colours

- White Satin
- Silver Grey
- Wild Oats
- Black Satin
- Graphite Ripple

Extended Colours

- Refer to Stronghold colour range

Options

- Other colours by request

Product Range

CODE	DESCRIPTION	DIMENSIONS (mm)
SLF 1004	4 Drawer Filing Cabinet	1320H x 900W x 480D
SLF 1003	3 Drawer Filing Cabinet	1020H x 900W x 480D
SLF 1002	2 Drawer Filing Cabinet	690H x 900W x 480D

NOTE: Special order only - minimum quantities apply.

Lateral Filing Cabinets



Features

- Strong steel construction
- Welded internal and base frame for extra strength and rigidity
- Heavy Duty 45kg ball bearing runners for smooth operation
- Full drawer extension for easy access to all files/contents
- Supplied with Anti Tilt system for safer operation
- Full height powder coated drawer body
- Drawer retention system ensures closed drawers stay shut
- Complete with two keys also Mastered locks available
- Durable oven baked, powder coat finish
- Adjustable Levelling Feet
- 2 rows of filing front to back or 1 row left to right
- Locking: Key Lock
- Warranty: 5 years

Colour Options

Standard Colours

- Standard Colours

Extended Colours

- Refer to Stronghold colour range

Options

- Planter Box

Product Range

CODE	DESCRIPTION	DIMENSIONS (mm)
SLF 1004	4 Drawer Filing Cabinet	1320H x 900W x 480D
SLF 1003	3 Drawer Filing Cabinet	1020H x 900W x 480D
SLF 1002	2 Drawer Filing Cabinet	690H x 900W x 480D

Mobile Pedestal – Budget



Features

- Files run laterally
- Warranty: 5 years

Colour Options

Standard Colours

- White Satin

Extended Colours

- Refer to Stronghold colour range

Other Colours

- By Request

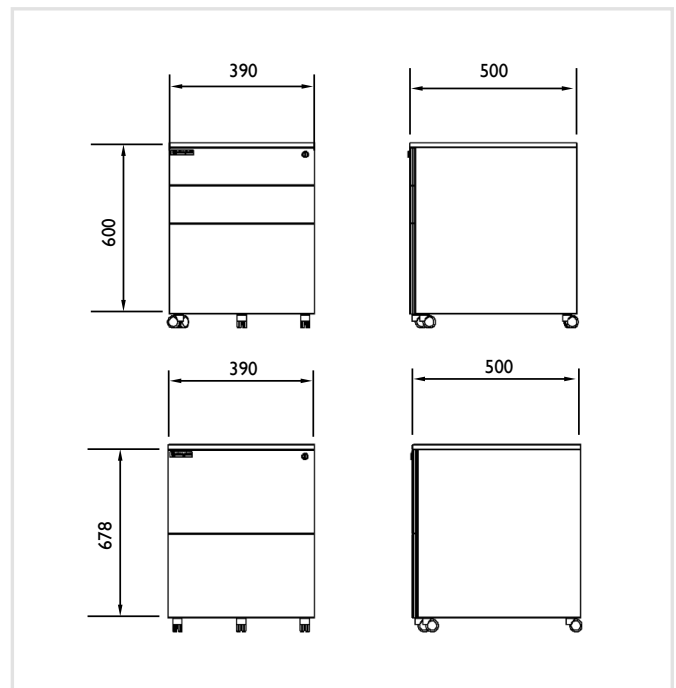

Product Range

CODE	DESCRIPTION	DIMENSIONS (mm)
SHP 3921	Flat Front, 2 Personal + 1 File, inc pencil tray	600H x 390W x 500D
SHP 3902	Flat Front, 2 File Drawers	678H x 390W x 500D

Mobile Pedestals

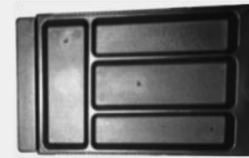

SH PT Pencil tray available

Features

- Strong all steel construction & Fully welded
- Double extension steel ball bearing runner system for smoother operation
- Full drawer extension for easy access to all files/contents
- Heavy-duty 35kg load capacity (UDL)
- A4 & foolscap hanging bar available in File Drawer
- High impact swivel castors – securely mounted on base
- Durable oven baked, powder coat finish
- Files run front to back
- Wide body for front to back filing
- Custom sizing available, min QTY applies
- Australian made
- Warranty: 5 years

Colour Options

Standard Colours

- Full Stronghold colour range

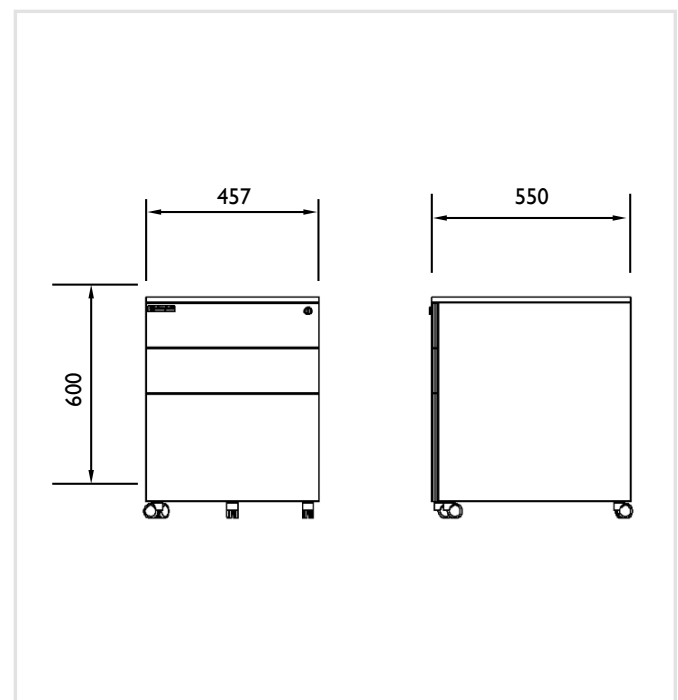

Product Range

CODE	DESCRIPTION	DIMENSIONS (mm)
SHP 4511	Low Profile, 1 Personal + 1 File, Recessed Handle	520H x 457W x 550D
SHP 4521	2 Personal + 1 File, Recessed Handle	600H x 457W x 550D
SHP 4522	2 File Drawer, Recessed Handle	660H x 457W x 550D
SHPT	Extendable Pencil Tray	To 400

Mobile Caddy



Features

- Strong all steel construction & Fully welded
- Full drawer extension for easy access to all files/contents
- Heavy-duty 35kg load capacity (UDL)
- High impact swivel castors – securely mounted on base
- Durable oven baked, powder coat finish
- Translucent Door Slats

Colour Options

Standard Colours

- White Satin
- Translucent Doors

Extended Colours

- Refer to Stronghold colour range

Other Colours

- By Request

Product Range

CODE	DESCRIPTION	DIMENSIONS (mm)
SPC 1046RH	Caddy - RHS Drawers	1050W x 460D x 570H
SPC 1046LH	Caddy - LHS Drawers	1050W x 460D x 570H
SPC 0945RH	Caddy 900W - RHS Drawers	900W x 450D x 600H
SPC 0945LH	Caddy 900W - LHS Drawers	900W x 450D x 600H

Tambour Cabinets



Features

- Strong steel construction
- Welded support frame for extra strength and rigidity
- Fully retractable tambour door system
- Full length magnetic catch on doors
- Easy slide moulded tracking
- Secure key locking
- Internal shelves and accessories are easily adjustable at 25mm increments
- Durable oven baked, powder coat finish
- Adjustable Levelling Feet
- 80kg shelf load
- Australian made
- Warranty: 5 years

Colour Options

Standard Colours

- White Satin/White Doors, Doors available in silver, Translucent, Charcoal & Magnolia upon request

Extended Colours

- Refer to Stronghold colour range

Other Colours

- By Request

Product Range

CODE	DESCRIPTION	DIMENSIONS (mm)
900 WIDE		
STM 0609	680H x 900W x 500D	1
STM 1009	1020H x 900W x 500D	2
STM 1209	1200H x 900W x 500D	2
STM 1309	1320H x 900W x 500D	2
STM 1909	1980H x 900W x 500D	4
1200 WIDE		
STM 0612	680H x 1200W x 500D	1
STM 1012	1020H x 1200W x 500D	2
STM 1212	1200H x 1200W x 500D	2
STM 1312	1320H x 1200W x 500D	2
STM 1912	1980H x 1200W x 500D	4

Tambour Accessories



Roll out frame



Roll out shelf

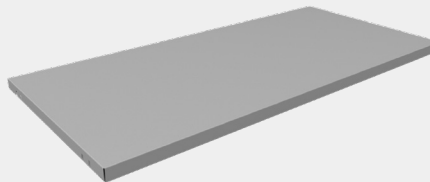

Extra Shelf

Colour Options

Standard Colours

→ Refer to Stronghold colour range

Extended Colours

→ By request

Other Colours

→ By request (Shelf & Shelf Divider only)

Product Range

CODE	DESCRIPTION	DIMENSIONS (mm)
900 WIDE		
STM 09SH	Shelf	To suit 900W
STM 09RS	Roll Out Shelf	To suit 900W
STM 09RF	Roll Out Frame	To suit 900W
SWR 0900	Wire Rack - 900W (White only)	740w
SWR 0900W	Wire Rack - 900W Wrap around (White only)	740w
1200 WIDE		
STM 12SH	Shelf	To suit 1200W
STM 12RS	Roll Out Shelf	To suit 1200W
STM 12RF	Roll Out Frame	To suit 1200W
SWR 1200	Wire Rack - 1200W (White only)	1040W
SWR 1200W	Wire Rack - 1200W Wrap around (White only)	1040W
GENERIC		
SSD 0500TAM	Shelf Divider 500D Tambour	To suit Tambour

Filing Accessories

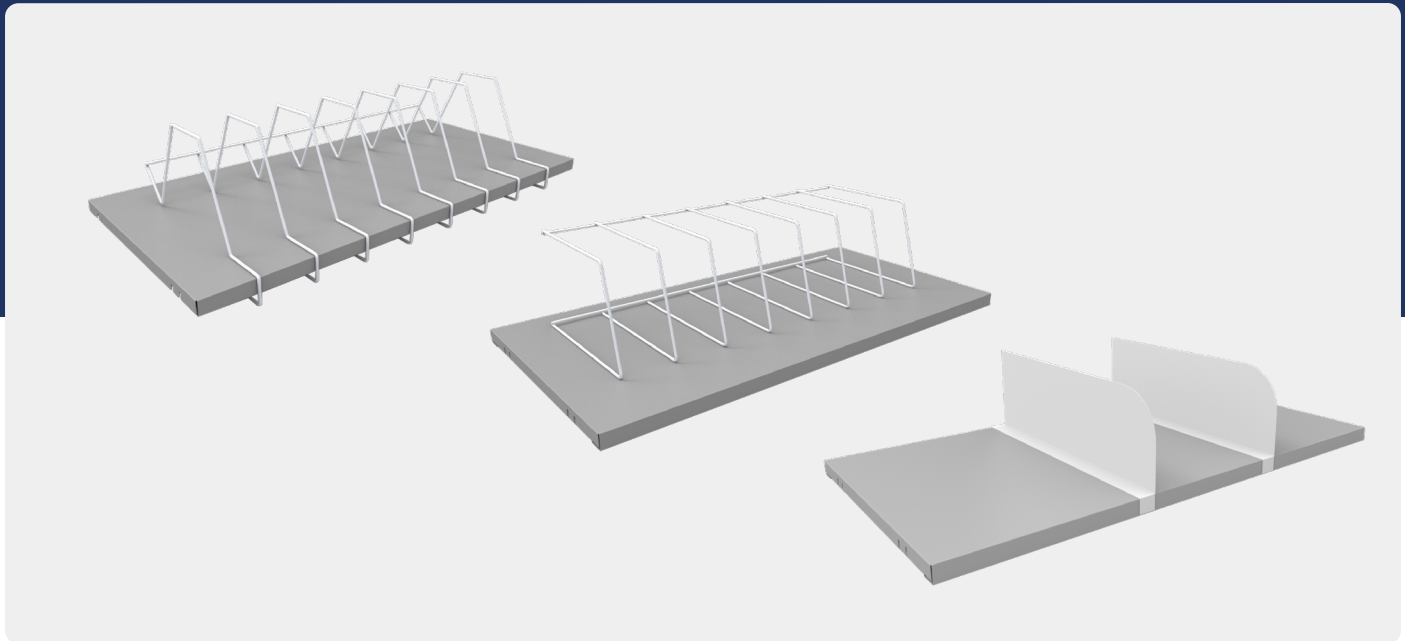

Features

- Shelf Divider
- Wire Rack
- Wire Rack Wrap around
- Australian made
- Warranty: 5 years

Colour Options

Standard Colours

- Wire Racks available in white only
- Shelf Divider refer to Stronghold colour range

Extended Colours

- Refer to Stronghold colour range

Other Colours

- By Request

Product Range

CODE	DESCRIPTION	DIMENSIONS (mm)
SWR 0900	Wire Rack - 900W (White only)	740w
SWR 0900W	Wire Rack - 900W Wrap around (White only)	740w
SWR 1200	Wire Rack - 1200W (White only)	1040w
SWR 1200W	Wire Rack - 1200W Wrap around (White only)	1040w
SSD 0350	Shelf Divider 350D	To suit 350D
SSD 0455	Shelf Divider 455D	To suit 455D
SSD 0500TAM	Shelf Divider 500D Tambour	To suit Tambour
SHPT	Extendable Pencil Tray	To 400mm

Desk Accessories



Desk Lozenge

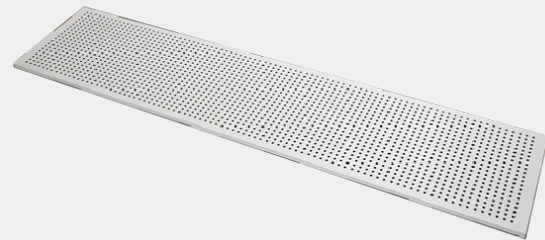

Modesty Panel Peforated

Features

- Desk Lozenge
- Modesty Panel Peforated
- Warranty: 5 years
- Australian made

Colour Options

Standard Colours

- Refer to Stronghold colour range
- Shelf Divider refer to Stronghold colour range

Extended Colours

- By Request

Other Colours

- By Request

Product Range

CODE	DESCRIPTION	DIMENSIONS (mm)
SHDL 25	Dek Lozenge - 25mm	25
SHDL 32	Desk Lozenge - 32mm	32
SMP 1500	Modesty Panel 1500W Plain	1500 x 400
SMP 1500P	Modesty Panel 1500W Perforated	1500 x 400
SMP 1800	Modesty Panel 1800W Plain	1800 x 400
SMP 1800P	Modesty Panel 2000W Perforated	1800 x 400
SMP 2000	Modesty Panel 2000W Plain	2000 x 400
SMP 2000P	Modesty Panel 2000W Perforated	2000 x 400

Planter Boxes



Features

- Fully welded steel
- Powder coated finish
- Plain or perforated
- Made to suit Tambours, Cabinets & Lateral Filing Cabs
- Plastic drip trays available
- Australian made
- Warranty: 5 years

Colour Options

Standard Colours

- Refer to Stronghold colour range

Other colours

- By request

Product Range

CODE	TO SUIT	SIZE	DIMENSIONS (mm)
SPB 09455	Cabinet	900 x 455 x 200	900 x 455 x 200
SPB 09455PE	Cabinet	900 x 455 x 200	900 x 455 x 200
SPB 09480	Lateral	900 x 480 x 200	900 x 480 x 200
SPB 09480PE	Lateral	900 x 480 x 200	900 x 480 x 200
SPB 09500	Tambour	900 x 500 x 200	900 x 500 x 200
SPB 09500PE	Tambour	900 x 500 x 200	900 x 500 x 200
SPB 12500	Tambour	1200 x 500 x 200	1200 x 500 x 200
SPB 12500PE	Tambour	1200 x 500 x 200	1200 x 500 x 200

Colours

Customise your design, and then pick the perfect colour for your application. Our expert product design team is happy to talk about colour matching or custom colour requests.

See our standard and prestige colour range below.

Standard colour range



Black Satin

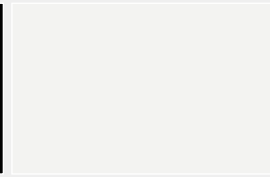

White Satin

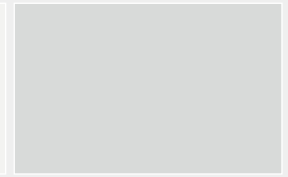

Silver Grey



Graphite Ripple



Wild Oats



Wedge Wood



Pottery

Extended colour range



Lawn Green



Blaze Blue



Signal Red



X15 Orange



Lemon Yellow

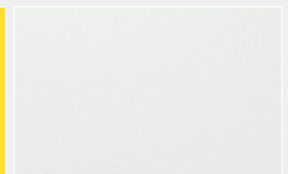

White Ripple

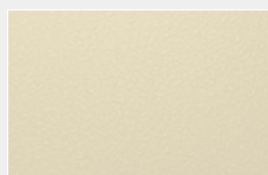

Beige Ripple

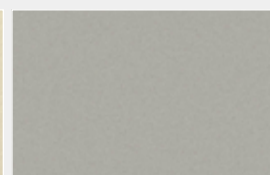

Silver Pearl

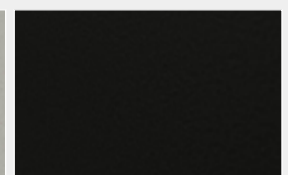

Black Ripple



Custom steel furniture, storage, cabinets and lockers. Robust, practical and Melbourne made.

Talk to us today.

PHONE 03 9357 0543

EMAIL info@stronghold.com.au

ADDRESS 9-13 Jesica Rd,
Campbellfield VIC 3061